

TZ1008S/TZ1012D

Toy Motor Driver Series

Features

- Low static operating current
- Wide supply voltage range: 2.5V-10V
- Continuous output current capability of 800mA /channel)
- Built-in thermal shutdown function
- Lower saturation voltage
- Has overtemperature protection function
- Three functions -Forward/Reverse/ High Impedance
- Compatible with TTL/CMOS interface, connects directly to CPU
- Built-in clamp diodes suitable for inductive load
- Control and drive circuit integrated into a single IC
- Suitable for 3 to 6 batteries operated application
- Internal ESD protection (4000V HBM)
- Operating temperature range: -20°C—+80°C

Typical Application

- Toy car motor drive

Description

The TZ1008S/TZ1012D is a dual-channel push-pull power amplification application-specific IC device designed to control and drive toy motor, integrates discrete devices into a monolithic IC, decreases cost of periphery, and increases reliability of the whole unit. All inputs of the chip are TTL/CMOS-compatible, and have a good interference immunity. The circuit has a greater current-driving capability, continuous current/channel is 750 mA to 800 mA, peak current reaches 1.5A to 2.0A, the circuit has overtemperature protection function, and on-chip clamping diode releases reverse impulse current of inductive load.

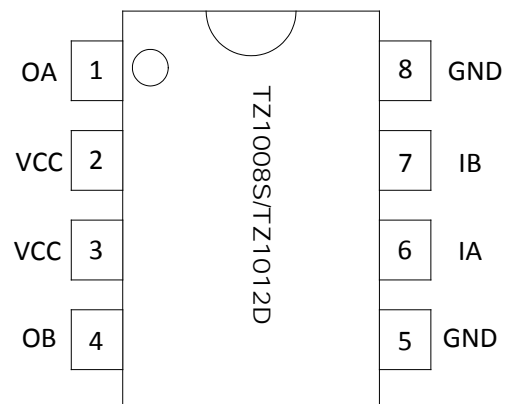

Ordering Guide

Device model	Package	Operating Temperature
TZ1008S/TZ1012D	SOP8	-20°C—+80°C
TZ1008S/TZ1012D	DIP8	-20°C—+ 80°C

Pin Function Descriptions

Pin Number	Mnemonic	I/O	Pin Function Description
1	OA	O	A channel output
2	VCC	-	Supply voltage output
3	VCC	-	Supply voltage output
4	OB	O	B channel output
5	GND	-	Ground
6	IA	I	A channel input
7	IB	I	B channel input
8	GND	-	Ground

FUNCTIONAL BLOCK DIAGRAM

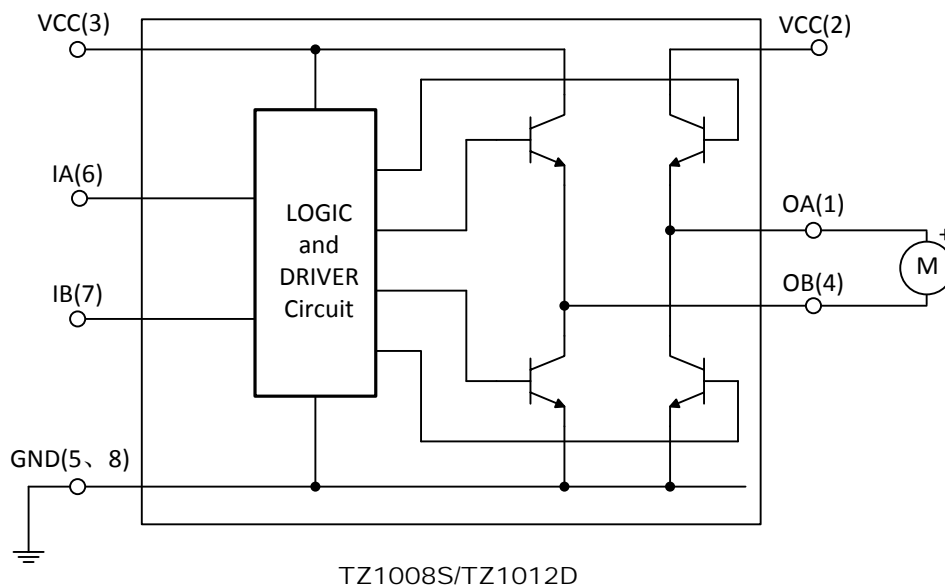

Schematics of Inputs and Outputs

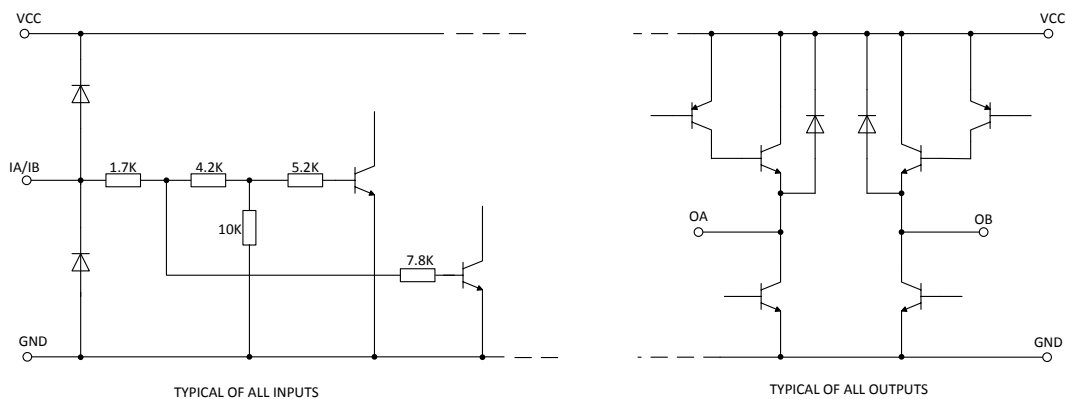

Logic Truth Table

IA	IB	OA	OB
H	L	H	L
L	H	L	H
L	L	Z (High Impedance)	Z (High Impedance)
H	H	Z (High Impedance)	Z (High Impedance)

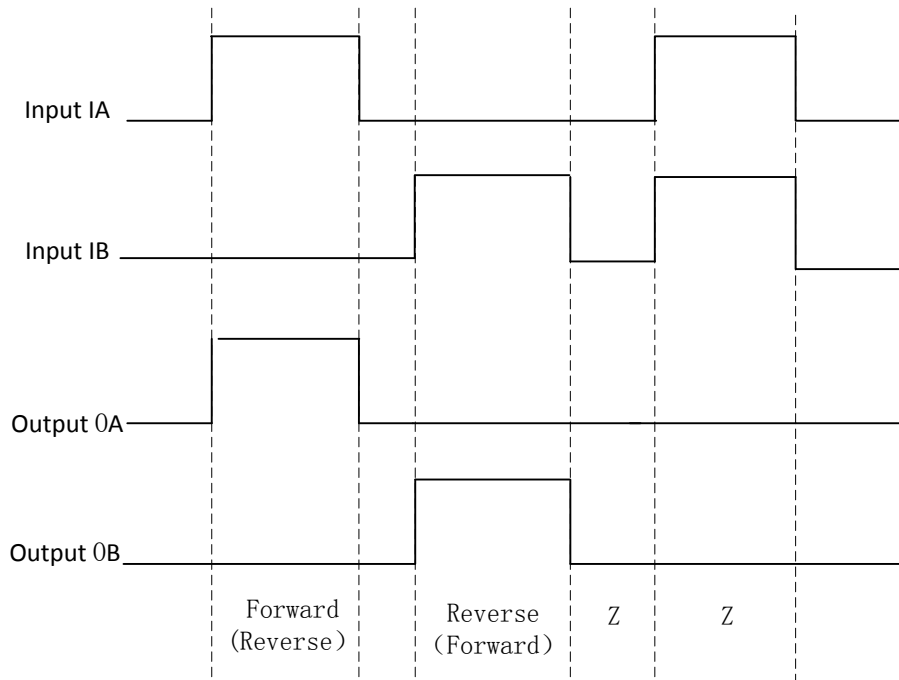

Absolute Maximum Ratings

($T_A=25^{\circ}\text{C}$, unless otherwise specified)

Parameter	Symbol	Value			Unit	
		Min.	Typ.	Max.		
Supply voltage	VCC	2.5	6.0	10	V	
Peak output current	I_{Max}	-	1500	2000	mA	
Input high level	V_{HIN}	2.5	5.0	10	V	
Input low level	V_{LIN}	-	0.5	0.7	V	
Thermal resistance ⁽¹⁾	θ_{JA}	SOP8	-	-	160	$^{\circ}\text{C}/\text{W}$
		DIP8	-	-	100	$^{\circ}\text{C}/\text{W}$
Maximum operating junction temperature	T_J	-	-	150	$^{\circ}\text{C}$	
Soldering temperature		-	-	260	$^{\circ}\text{C}, 10\text{S}$	
Storage temperature Range	Tstg	-65	-	150	$^{\circ}\text{C}$	

NOTE: (1) Maximum power dissipation can be obtained from the following formula

$$P_D = (T_J - T_A) / \theta_{JA}$$

Where T_J is junction temperature with the circuit working, and T_A is the ambient temperature with the circuit working. Calculation of thermal impedance of package is as per ESD 51-7.

Recommended Operating Conditions

($T_A=25^{\circ}\text{C}$, unless otherwise specified)

Parameter	Symbol	Condition	Range			Unit
			Min.	Typ.	Max.	
Supply voltage	VCC		3.0	-	9.0	V
Continuous output current	I_{OUT}		400	600	800	mA
Operating temperature range ⁽¹⁾	T_A		-20	-	80	$^{\circ}\text{C}$
Power dissipation ⁽²⁾	P_D	SOP8	-	-	625	mW
		DIP8	-	-	1250	mW

NOTES: (1) T_A is the ambient temperature at the time that circuit operates;

(2) The power dissipation P_D is given by:

$$P_D = I_{\text{OUT}} \times V_{\text{O(sat)}} + (I_{\text{VCC}} - I_{\text{OUT}}) \times V_{\text{CC}} + V_{\text{IA}} \times I_{\text{IA}} + V_{\text{IB}} \times I_{\text{IB}}$$

where I_{OUT} is the output current through the circuit or driving motor; $V_{\text{O(sat)}}$ is output saturation voltage of circuit; I_{VCC} is the current flowing into power supply pin VCC; VCC is the voltage at power supply pin VCC; V_{IA} and V_{IB} are the input voltage at power supply pins IA and IB, respectively; I_{IA} and I_{IB} are the input current at power supply pins IA and IB, respectively.

In above expression, P_D is mostly determined by $I_{\text{OUT}} \times V_{\text{O(sat)}}$, where for the relation between output saturation voltage $V_{\text{O(sat)}}$ and output current I_{OUT} of circuit the typical parameter curves in Fig. 6 can be referred to. If the internal resistance of a motor is R_M , then a straight line $V_{\text{O(sat)}} = V_{\text{CC}} - I_{\text{OUT}} \times R_M$ is drawn in Fig. 6. From the point of intersection of the straight line with the curve in Fig. 6, $V_{\text{O(sat)}}$ and I_{OUT} can be obtained. In combination with practical application and power dissipation, internal resistance of a motor (R_M) is determined, and so a proper motor can be selected.

To make circuit operate safely and normally, make sure that circuit power dissipation is in the range allowed.

Electrical Characteristics

(Unless otherwise specified, $V_{CC}=5V$, $T_A=25^\circ C$)

Parameter	Fig. for test	Condition	Min.	Typ.	Max.	Unit
I_{DD} Quiescent current	1		-	0.1	2.0	μA
I_{IN} Input current	2	$V_{IA}=H, V_{OA}=H$	-	500	700	μA
$V_{O(sat)}$ Output saturation voltage ⁽¹⁾	3	$I_{OUT}=500mA^{(2)}$	-	1.00	1.15	V
		$I_{OUT}=200mA$	-	0.75	0.85	V
I_{OUT} Continuous output current	3	SOP8	750	800	850	mA
		DIP8	900	1000	1100	mA
I_{Max} Peak output current	3		-	1500	2000	mA
T_{sd} Over-temperature shutdown		$V_{CC}=6V$		165		$^\circ C$
T_{sdh} Over-temperature shutdown hysteresis		$V_{CC}=6V$		30		$^\circ C$

NOTES: (1) The output saturation voltage is the sum of output high- and low-side saturation voltages, i.e. the sum of the measured values in voltmeters V1 and V2 in Fig.3.

(2) By adjusting adjustable resistor R in Fig. 3, the stated current can be obtained from reading of ammeter.

Test Circuit Diagrams

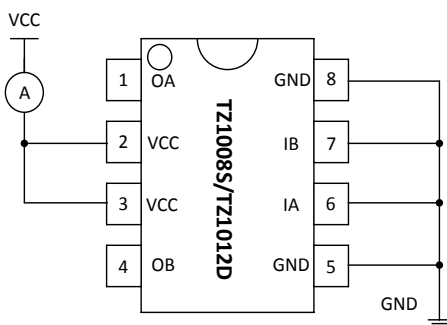

Fig. 1 (Quiescent current I_{DD})

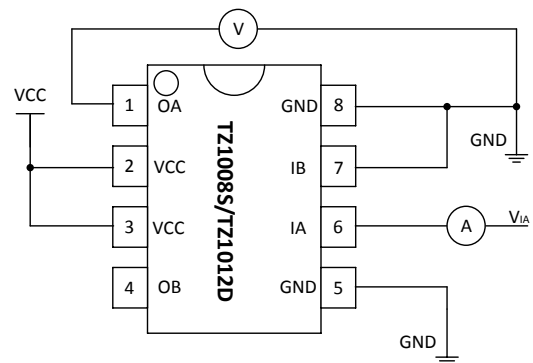

Fig. 2 (Input current I_{IN})

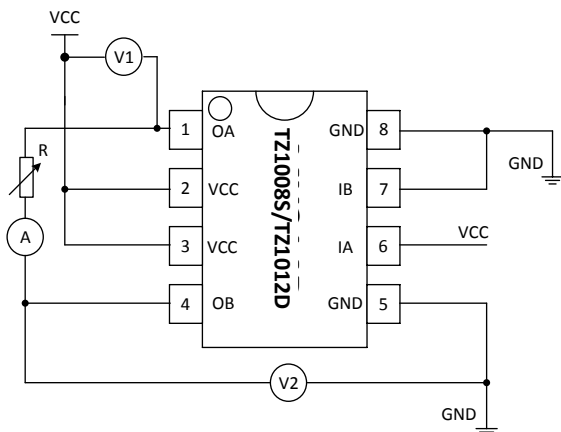

Fig. 3 (Output saturation voltage $V_{O(sat)}=V1+V2$)

Typical Electrical Characteristic Curves

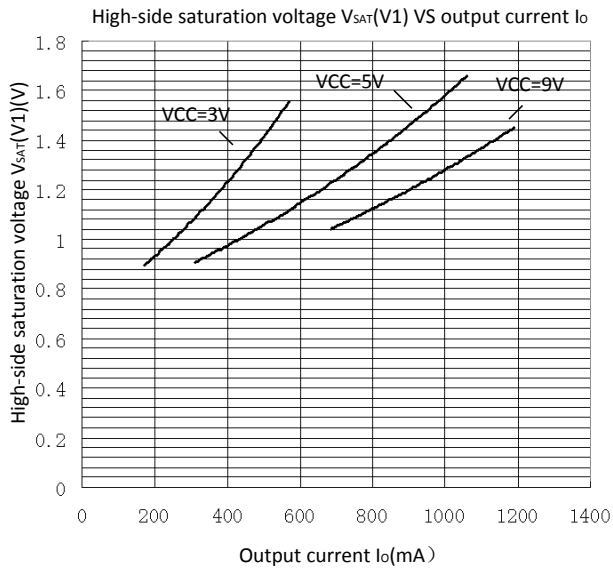

Fig. 4 High-side saturation voltage VS output current

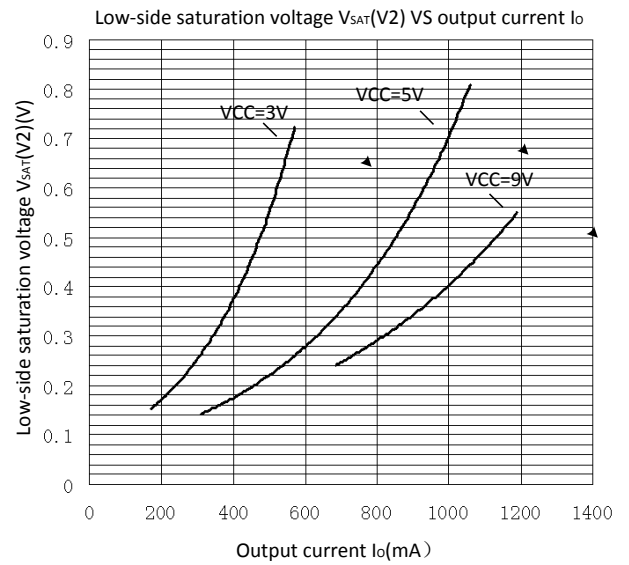

Fig. 5 Low-side saturation voltage VS output current

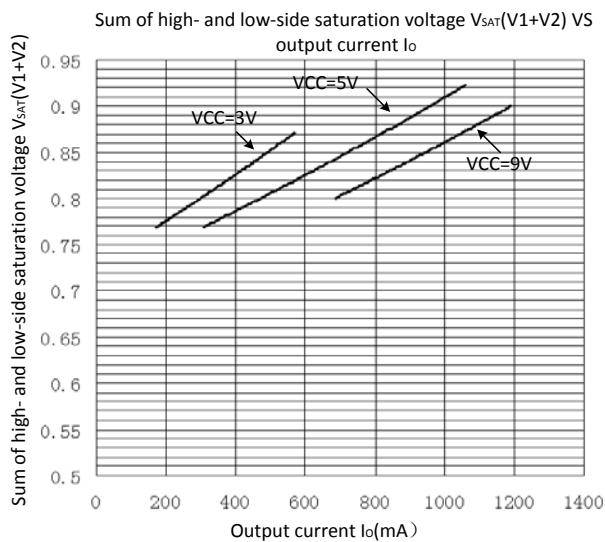

Fig. 6 Sum of high- and low-side saturation voltage VS output current

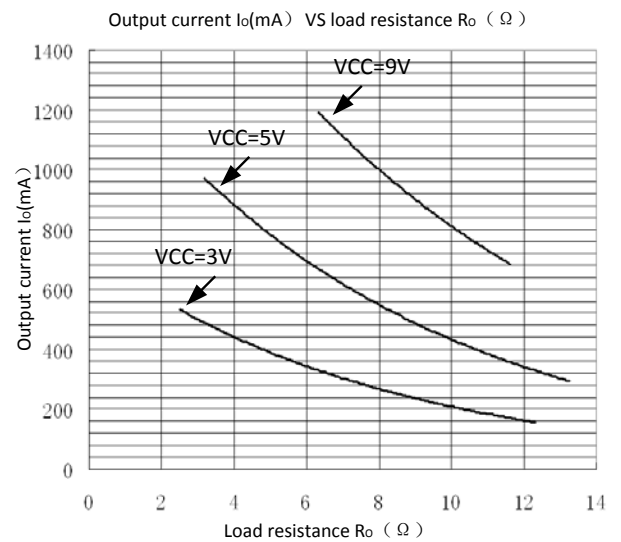
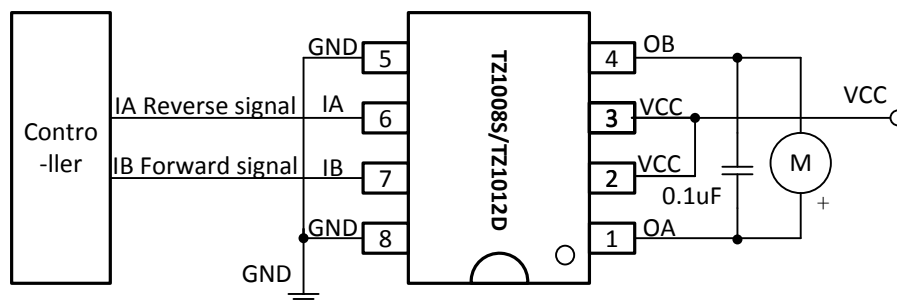

Fig. 7 Output current VS load resistance

Typical Application Circuit Diagrams



Packages

SOP8:

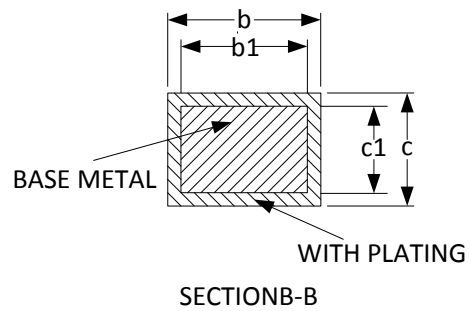
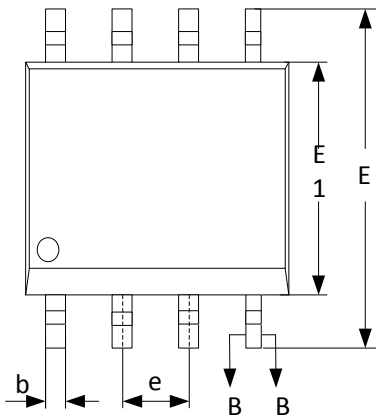
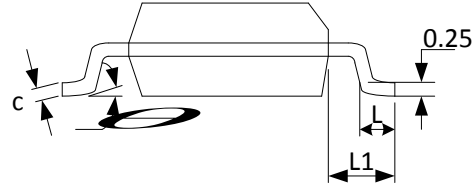
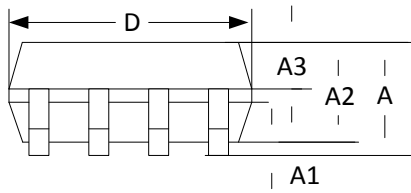

SYMBOL	MILLIMETER		
	MIN	NOM	MAX
A	--	--	1.77
A1	0.08	0.18	0.28
A2	1.20	1.40	1.60
A3	0.55	0.65	0.75
b	0.39	--	0.48
b1	0.38	0.41	0.43
c	0.21	--	0.26
c1	0.19	0.20	0.21
D	4.70	4.90	5.10
E	5.80	6.00	6.20
E1	3.70	3.90	4.10
e	1.27BSC		
L	0.50	0.65	0.80
L1	1.05BSC		
θ	0	--	8°

DIP8:

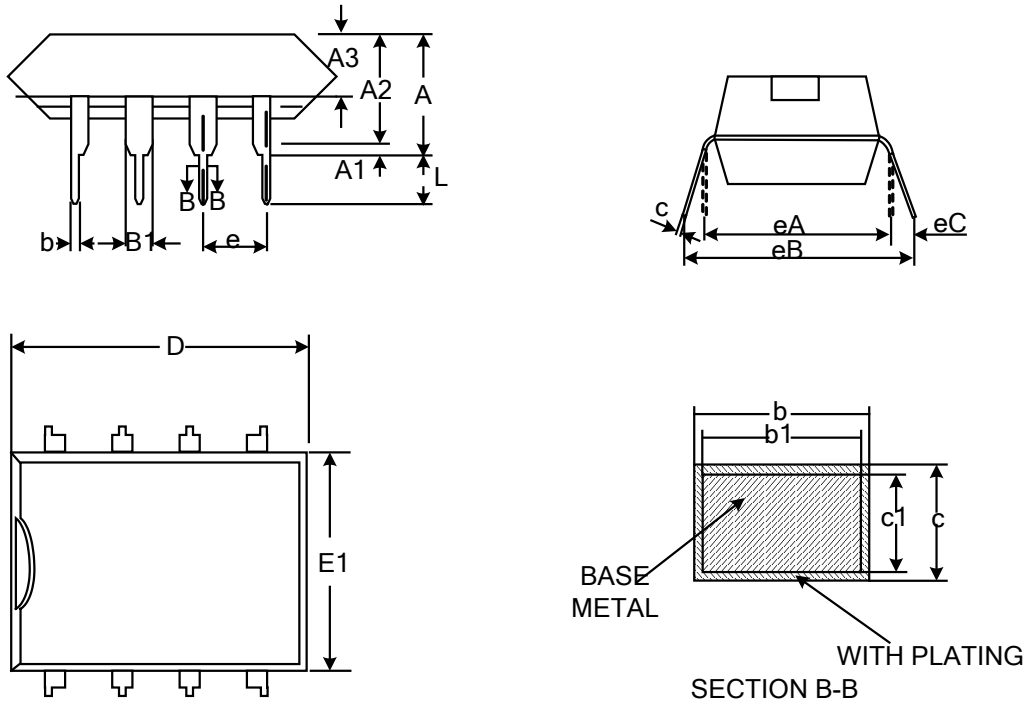

SYMBOL	MILLIMETER		
	MIN	NOM	MAX
A	3.60	3.80	4.00
A1	0.51	—	—
A2	3.10	3.30	3.50
A3	1.50	1.60	1.70
b	0.44	—	0.53
b1	0.43	0.46	0.48
B1	1.52BSC		
c	0.25	—	0.31
c1	0.24	0.25	0.26
D	9.05	9.25	9.45
E1	6.15	6.35	6.55
e	2.54BSC		
eA	7.62BSC		
eB	7.62	—	9.50
eC	0	—	0.94
L	3.00	—	—